

USER MANUAL

MIG TRANSIT SPRAYER 70



To safely operate the MIG Transit Sprayer 70 device to its full operational capacity ensure that all instructions and warnings have been read and understood.



Product Introduction



The MIG Transit Sprayer 70 device is designed to operate in line with the shielding gas flow of the MIG/MAG welding process to provide a continuous mist generated by fluid in a sealed chamber and passed directly to the welding torch. This is achieved by inserting the unit into the gas line after the gas solenoid situated in the wire feed unit.

MIG ANTI-SPATTER TECHNOLOGY CREATED IN THE WELDING CELL

INSTALLATION INSTRUCTIONS

Positioning on the robot

1. Turn off and isolate the robot system from the mains supply. The robot must be in the HOME position.
 2. Mount the MIG Transit Sprayer 70 to the robot at a 45 degrees angle as shown in the image below as closely practical to the gas solenoid.
- Ensure that when mounted, the unit cannot be harmed or damaged by any obstructions when the robot is in operation.

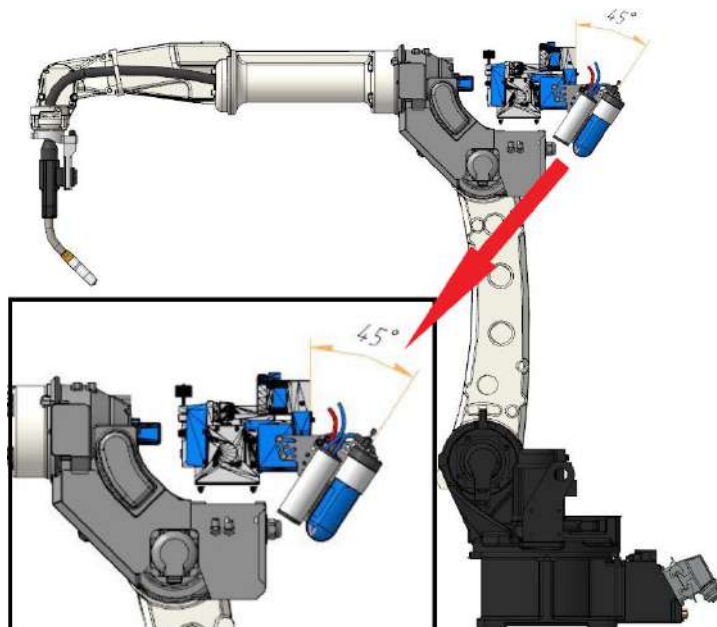

Shielding Gas Connections

1. Cut or remove the gas hose to the welding torch in a position AFTER the gas solenoid in the Wire Feed Unit.

Important note: NEVER attempt to fit the MIG Transit Sprayer 70 before the Gas Solenoid as the unit will not operate correctly in this configuration.

2. Connect the **Blue Gas Pipe** from the MIG Transit Sprayer 70 indicated “**IN**” to the output of the gas solenoid. Connect the **Red Gas Pipe** from the device indicated “**OUT**” directly to the hose uncoupled from the gas solenoid which then goes to the welding torch.

E n s u r e a l l c o n n e c t i o n s a r e t i g h t a n d d o n o t l e a k .



3. Remove the small cap on the top of the chamber with the 2 mm Allan Key supplied. Empty the 70 ml refill of Active Shield fluid into the chamber. Fill the chamber to a maximum of 70 ml and put the cap back on.

4. When supplied, the throttle - which regulates the amount of the generated protective mist placed on the top of the generating chamber - is set at CLOSED. Prior to operation open the throttle to approximately 50%.

5. Prior to operating the MIG Transit Sprayer 70 a shielding gas flow rate must be set at the Gas Nozzle on the welding torch and can only be set accurately by using a Flow Gauge directly coupled to the Gas Nozzle. Depending on the welding application the MIG Transit Sprayer 70 can operate at gas flow rates from 12-36 Litres per minute of gas flow.

6. Activate the shielding gas with the pre flow/purge option on the welding power source and set the incoming gas flow required by using the readings on the flow gauge at the Gas Nozzle. A gas flow rate can never be set accurately by the incoming regulator at the back of the welding cell as various different lengths of gas hoses will directly affect the gas flow rate at the gas nozzle.

Note: Gas Savers should not be used when using this device as gas flow starvation can occur and when using the MIG Transit Sprayer 70 any excessive incoming gas pressure is naturally deflected by this unit thus making any Gas Savers redundant.

7. The required amount of generated mist can now be set by using the Throttle on top of the chamber. Only sufficient mist to control any spatter adhesion must be used as any levels of excessive mist used can have an adverse effect on the weld pool.

OPERATING INSTRUCTIONS

1. Only use fluid specifically designed for use with the MIG Transit Sprayer 70. Do not overfill the Chamber or operate when empty. Refill to a maximum of 70 ml when the chamber is empty. Do not exceed the marked level.
2. To refill the Chamber, carefully unscrew the cap and fill to the maximum level marked on the left .
3. Keep the fluid level above the minimum line marked on the device.
4. Adjustment of the mist concentration- a specially designed pneumatic throttle with a chrome lever for fine-tuning is mounted on the top of the generating chamber. The adjustment lever ensures lightly setting up the mist concentration from 0% to 100% without breaking down the gas flow.

5. ADJUSTMENT ORDER

- a. The chrome lever for fine-tuning the level of the protective mist is normally closed.
- b. By using a gas pre-purge start carefully turning the lever towards the opened position until you observe the formation of bubbles and mist above the fluid level in the transparent chamber.
- c. Adjust to the maximum level of the protective mist. In some cases you can see it coming out of the welding gun /gas nozzle/. The mist can be seen with the naked eye with a dark background and is light and fine. It is easier to see at the end of the welding cycle when the gas flow decreases. Leave the adjustment set this way.
- d. Start welding. After some hours check inside the gas nozzle and the contact tip. If their surfaces are too oily decrease the adjustment with one/two turns.
- e. Repeat this action if necessary.

SAFETY REQUIREMENTS

1. The incoming welding gas pressure flow regulator must be in good working order and calibrated. A gas solenoid usually located inside the wire feed unit of the welding machine must be in good working order. Never operate with faulty pressure control equipment.
2. The welding gun must be clean and free from contamination.
3. The gas hoses to the device must be in good working condition and regularly cleaned to remove foreign matter.
4. Operational gas flow rate is between 12 l/min – 36 l/min and is set with a flow meter set at the gas nozzle.
5. Always install the MIG Transit Sprayer 70 **AFTER the gas solenoid**.
6. The gas outlet of MIG Transit Sprayer 70 must be an unrestricted connection to the weld gun.
7. Never reverse the gas lines connections to the Unit.
8. When working with MIG Transit fluid, always wear an approved respirator, solvent resistant gloves, eye protection, oil resistant clothing and footwear. (see Safety Data Sheet).
9. Do not overfill the Chamber or do not operate the Unit under the indicated minimum level. When necessary, refill the chamber to the 70 ml maximum level marked on it.
10. The device must be installed in a 45 degree position on the robot.
11. Do not use MIG Transit Sprayer 70 **when welding Aluminium**.
12. Never attempt to use a substitute fluid. The fluid is unique and is not compatible with other anti-spatter fluids and will consequently void any such warranty.
13. During operation do not combine with any other fluids relating to spatter control. Some robot systems have an air-blast at the end of the welding cycle. Never use any air-blast systems through the MIG Transit Sprayer 70.
14. Use in a well-ventilated environment or use an appropriate exhaust system to remove fumes from the breathing zone.
15. Read, understand and comply with all directions and warning labels.
16. Additional safety information you may find in the detailed Safety Data Sheet.

